

Roland

MULTI-FORMAT AV MIXER

# VR-50HD

An all-in-one HD Multi-Format AV Mixer with  
built-in USB 3.0 for Web Streaming and Recording





# A complete portable HD studio in a single unit.

Single-person operation of sound and picture using faders, buttons and touch screen.

The Roland VR-50HD all-in-one AV mixer beautifully integrates an audio mixer, video switcher, multi-viewer touch screen and USB video/audio streaming into a stand-alone device.

This single unit delivers functionality that until now required a number of peripheral devices to accomplish. This portable live HD production solution is ideal for schools, churches, council meetings, corporate events, sports, trainings, or any other live event.



# VR-50HD

MULTI-FORMAT AV MIXER **SDI** **HDMI** **RGB** **SD** **AUDIO**



**12 input, 4-Channel Multi-Format Video Switcher**

- 12 input, 4-Channel Video plus still channel Multi-Format Switcher
- Supports 3G/HD/SD SDI, HDMI, RGB/Component, and Composite Video Inputs Up to 1080p (3G SDI)
- Embedding of audio with delay settings
- 12-Channel Digital Audio Mixer with XLR, TRS, and RCA jacks along with audio from SDI and HDMI inputs
- 4 Layer, Compositing of PinP, PinP/KEY, and STILL
- Built-In Preview Touch Monitor (7 inch Graphic color LCD 800 x 480 dots)
- External Multi-View Output through HDMI
- HDCP Support
- USB3.0 Video/Audio Output for web streaming and recording up to 1080p (uncompressed)

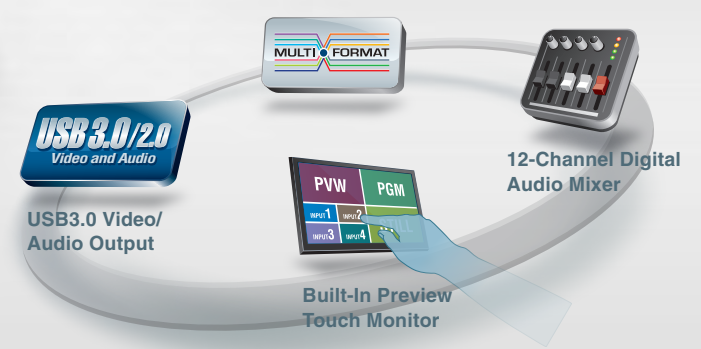



# 12-Channel Digital Audio Mixer

The design of the VR-50HD places the audio mixer on the left and the video sw Dedicated audio faders and simple touch screen to select video gets you work

## The advanced "Touch & Turn" surface

Pressing the Setup button above a fader displays advanced settings for the corresponding channel letting you make settings for parametric equalizer, audio delay, reverb, and more. The "touch & turn" feature makes parameters easy to change by touching the corresponding knob on the display and turning the physical Value knob.



## Audio Input via HDMI and SDI Signals

Using faders 5 through 12, you can freely switch between line, HDMI, and SDI input at any time. This enables maximum flexibility and changes of inputs to match whatever might be required from the content. Using the "Audio Follow" feature, you can make the audio switch automatically from one source to another as the video source changes.

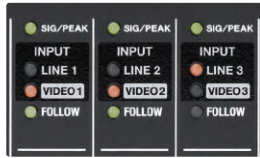

## Digital Effects

Audio processing from Roland professional mixers includes gates, compression, PEQ, delay, reverb and even mastering capabilities on the main output. The delay is useful for adjustment of lip-sync between video and audio from external mics.



● Top Panel

## AUDIO Output

SDI, HDMI: Linear PCM, 24bit, 48kHz, 2ch USB: Linear PCM, 16bit, 48kHz, 2ch

Audio is mixed and re-embedded into the SDI, HDMI, and analog outputs as well as the USB output. Each of the outputs are assignable from the Main bus or Aux bus.

## USB STREAMING Output

Uncompressed up to 1080/59.94p (USB3.0), up to 720/29.97p (USB2.0)

The resolution and frame rate of the video format can be changed thanks to the dedicated scaler for the USB output.

Output is assignable from PGM or AUX bus.

## HDMI MULTI-VIEW Output

1080/59.94p with HDCP  
Seven-way multi-viewer

## HDMI Output

Up to 1080p  
HDCP support  
Each of the outputs are assignable from PGM, PVW, or AUX bus.



● Rear Panel

# 12 input, 4-Channel Multi-Format Video Switcher

itcher on the right.  
ing right away without any special knowledge.



## Built-In Preview Touch Monitor

The large 7-inch touch panel can be switched between seven-way multi-view, the various inputs, still picture, and program out. You can switch by directly touching the video you want to select while viewing full-frame multi-view output-extremely easy operation.



## Transition Effects

You use cuts, mixes, and wipes by switching using the Transition buttons. The Time dial lets you instantly apply an effect time of 0 to 4 seconds. Even without a T-bar, it's possible to achieve flexible switching.



## Composition Feature

The Composition buttons let you accomplish instant inserts for picture-in-picture, title compositions using chroma key or luminance key, and even key compositing from a still picture imported into the unit's internal memory. You can use the Setup buttons to change detailed settings.

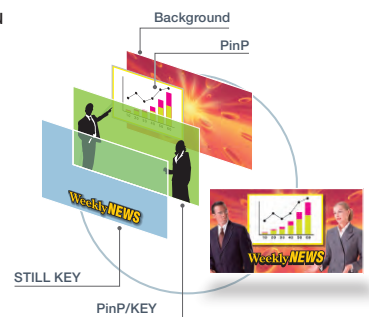

### AUDIO Input

SDI, HDMI : Linear PCM, 24bit, 48kHz, 2ch  
12 analog inputs or from audio embedded in the 4 SDI or 4 HDMI inputs. The XLR jacks are provided with selectable phantom power.

### RGB/COMPONENT Input/Output

Up to 1080p

### COMPOSITE Input

NTSC or PAL

### HDMI Input

Up to 1080p  
HDCP support

### 3G/HD/SD SDI Input/Output

Up to 1080p  
3G SDI supports Level A and B.  
Each of the outputs are assignable from PGM, PVW, or AUX bus.

\*For details about supported formats, refer to the specifications on the back cover.





## AV Studio and Live Streaming

Until now, achieving a high-definition AV studio with live streaming required a large amount of equipment: video switchers, audio mixers, converters for adjusting the input signals of devices with different resolutions, LCD monitors, and so on.

### The VR-50HD is an all-in-one device — a complete high-definition production center in a single unit.

You can connect cameras, computers, Blu-ray players, DVD players, microphones, iPads, and more for use as input devices, without having to worry about whether the equipment is analog or digital or what formats they output. In addition to HD-SDI and HDMI output for HD recording equipment, the unit also provides USB 3.0 and 2.0 output. This enables the ability to connect a computer and perform live streaming and recording. All digital video output connectors include embedded audio as well.

#### ▶ Application example

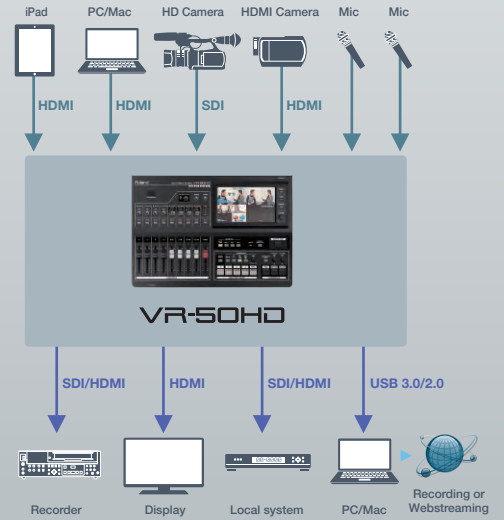

### 12 input, 4-Channel Multi-format Video Switcher

At total of 12 HDMI, 3G/HD/SD-SDI/SDI, RGB/COMPONENT, and composite inputs are provided. In addition to professional HD cameras, you can connect equipment that ranges from computers and Blu-ray and DVD players to video cameras using composite output. The unit features multi-format specifications that allows you to never have to worry about differences in resolution among input devices.

\*6 channel switching is possible when not using compositing features such as PinP and Key.



### Built-In Preview Touch Monitor

The VR-50HD is equipped with a large 7-inch touch-panel LCD screen that enables truly intuitive operation. Using the seven-way multi-viewer to display four input pictures, composited material, and program out simultaneously eliminates the need for external monitors. You can also switch to quad multi-view. Advanced settings for picture and sound can also be made using the touch panel, so you can get started right away without having to read the manual.

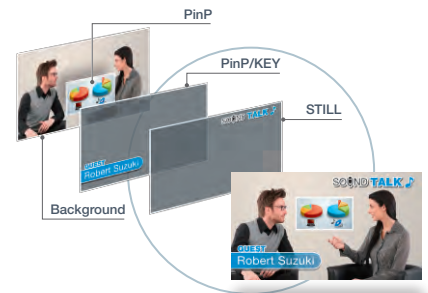

### Four Layer Composition

The composition feature supports a total of four layers. This lets you place keyed video on picture-in-picture, then also superimpose a still picture imported into the unit's internal memory over that. PinP and key compositing use independent scalers, so you can adjust the positions and sizes however you like. You can switch the effects on and off at any time using the dedicated composition buttons. You can set the order of succession for PinP, PinP/KEY, and STILL to your preference.

\*The VR-50HD can store up to 4 still images in the internal memory.  
\*STILL position and size compositing can not be adjusted.





## Presentations and Live Events

You never know what kind of material on what devices/media will be brought to a presentation or live event. The notebook computers that presenters bring can have a variety of connectors from VGA to DVI, HDMI, and others. Resolutions are also diverse, and quick accommodation is not always possible. Use of commercially available Blu-ray discs and DVDs can also run into the problem of playback being restricted by HDCP.

**The VR-50HD resolves such issues without the need for any additional equipment.**

Even when input devices use different resolutions, internal scalers perform automatic conversion to the optimal resolution. The built-in scalers also let you expand and reduce video and still images however you like for perfect framing. The VR-50HD features an HDCP mode that lets you input and switch commercial digital video from sources such as Blu-ray discs or game consoles encoded using HDCP digital copyright management technology. This is a multi-format AV mixer that you can count on to handle whatever material turns up on-site.

\*In HDCP mode, only HDMI output can be used. Use of SDI, RGB/Component, Composite, analog audio output is not possible.  
\*Commercial use of content requires the permission of the copyright-holder.

### ► Application example

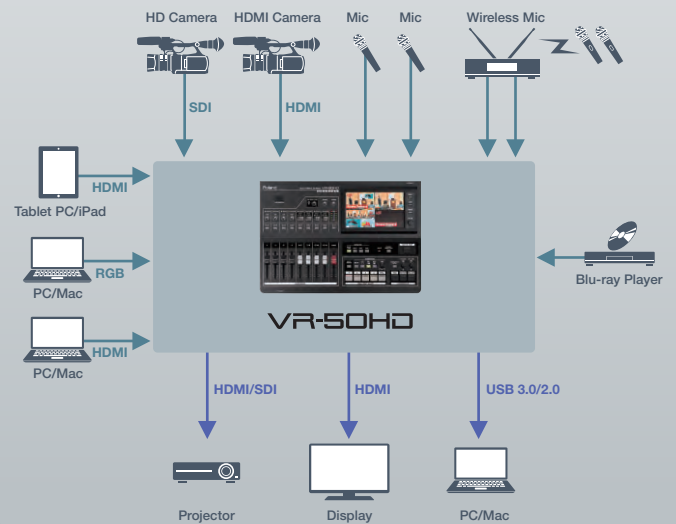

### 12-Channel Digital Audio Mixer

The VR-50HD features a 12-channel digital audio mixer that mixes audio from cameras in addition to sound from four microphones, computers, and DVD players. Capturing and mixing 3G/HD/SD-SDI/HDMI audio in the audio mixer is also possible. Using the "Audio Follow" feature, you can even make the audio switch automatically from one source to another as the video source changes. Built-in delay and equalizer features make possible a broad range of use, from seminars to musical events.



### USB3.0 Video/Audio Output

The USB 2.0/3.0 output enables web streaming with ease by simply connecting to a computer running a live streaming service. Recording is equally simple by using QuickTime or the dedicated Windows/Mac capture software, the Video Capture for VR. The video format is up to 1080/59.94p through USB3.0 and up to 720/29.97p through USB2.0. The resolution and frame rate of video format and audio level and delay can be changed thanks to the dedicated scaler and the dedicated volume and delay for the USB output.

### Video Capture for VR

Video Capture for VR is application software that captures video and audio signals output from the VR-50HD USB port and saves them to movie files on your connected Windows/Mac.



Free download from  
[www.rolandsystemsgroup.net](http://www.rolandsystemsgroup.net)



## Specifications

Processing	4:4:4 (RGB), 10-bit 4:2:2 (Y/Pb/Pr), 10-bit	Effects	Transition: Mix, Cut, Wipe (9 patterns) Composition: PinP, Chrominance Key Others: Output Fade, Output Freeze, User Logo	
Video	Input Connectors	3G/HD/SD-SDI: BNC type x 4 (INPUT 1-4) * Conforms to SMPTE 424M (SMPTE 425M-AB), 292M, 259M-C. HDMI(DVI-D): Type A(19pin) x 4 (INPUT 1-4) * HDCP Supported. Analog Video SD: Mini D-sub 15-pin type x 2 (INPUT 1-2) Analog Video (SD): Composite (BNC type) x 2 (INPUT 1-2) * INPUT 1-2: Select SDI, HDMI or Analog RGB, Composite using menu. * INPUT 3-4 : Select SDI, HDMI using menu.	Audio Processing	Sampling Rate: 24-bit/48 kHz
	Output Connectors	3G/HD/SD-SDI: BNC type x 2 (PGM OUT, AUX OUT) * Conforms to SMPTE 424M (SMPTE 425M-AB), 292M, 259M-C HDMI(DVI-D): Type A(19pin) x 3 (PGM OUT, AUX OUT, MULTI VIEW) * HDCP Supported Analog RGB/HD-Component: Mini D-sub 15-pin type x 2 (PGM OUT, AUX OUT)	Input Connectors	AUDIO IN (1 to 4) jacks (XLR/TRS combo type) * XLR type: 1 GND , 2 HOT , 3 COLD * Phantom Power: DC 48 V (unloaded maximum), 5 mA (maximum load) (Current value per channel). AUDIO IN (5 to 8) jacks (RCA phono type) AUDIO IN (9 to 12) jacks (TRS type)
	Input/Output Level and Impedance	Composite: 1.0 Vp-p 75 ohms Analog RGB: 0.7 Vp-p 75 ohms (H, V: 5 V TTL) Analog HD: 1.0 Vp-p 75 ohms (Sync-Signal: Bi-Level/Tri-Level)	Output Connectors	AUDIO OUT L/R jacks (XLR-3-32 type) * XLR type: 1 GND , 2 HOT , 3 COLD AUDIO OUT L/R jacks (RCA phono type) PHONES jack (Stereo 1/4-inch phono type) PHONES jack (Stereo miniature type) (headphones)
Supported Video Formats	SDI: 480/59.94i, 576/50i, 720/59.94p, 720/50p, 1080/59.94i, 1080/50i, 1080/59.94p, 1080/50p * Conforms to SMPTE 274M, SMPTE 296M, ITU-R BT601-5. HDMI(*2) 480/59.94i, 576/50i, 480/59.94p, 576/50p, 720/59.94p, 720/50p, 1080/59.94i, 1080/50i, 1080/59.94p, 1080/50p 1024x768/60Hz(*1), 1280x720/60Hz(*1), 1280x800/60Hz(*1), 1280x1024/60Hz(*1), 1400x1050/60Hz, 1920x1080/60Hz HDMI(MULTI-VIEW Output)(*2) 1080/59.94p Component: 480/59.94i, 576/50i, 480/59.94p, 576/50p, 720/59.94p, 720/50p, 1080/59.94i, 1080/50i, 1080/59.94p, 1080/50p RGB(*2) 1024x768/60Hz(*1), 1280x720/60Hz(*1), 1280x800/60Hz(*1), 1280x1024/60Hz(*1), 1400x1050/60Hz, 1920x1080/60Hz Composite NTSC, PAL * Conforms to ITU-R BT601-5. *1 Output refresh rate is 75 Hz when frame rate is set to 50 Hz. *2 Conforms to CEA-861-E or VESA DMT Version 1.0 Revision 11. * The video signal frame rate must match the unit's frame rate setting. * The output format of HDMI and RGB/Component is always the same. When a Video format is selected, component signal is output from the RGB/COMPONENT connector. When a RGB format is selected, RGB signal is output from the RGB/COMPONENT connector. USB-VIDEO : 480/29.97p , 576/25p , 480/59.94p , 576/50p , 720/29.97p , 720/25p , 720/59.94p , 720/50p , 1080/29.97p , 1080/25p , 1080/59.94p , 1080/50p Still Image: Windows s' Bitmap File (bmp) * Maximum 1920 x 1080 pixels, 24-bit per pixel, uncompressed.	Audio	Input Level and Impedance	XLR/TRS: -68 to +4 dBu (Maximum: +22 dBu, 4 k ohms) RCA phono: -10 dBu (Maximum: +8 dBu, 11 k ohms) TRS: +4 dBu (Maximum: +22 dBu, 98 k ohms)
	Audio Formats	SDI: Linear PCM, 24bit, 48kHz, 2ch * SMPTE 299M, SMPTE 272M-C HDMI: Linear PCM, 24bit, 48kHz, 2ch USB-AUDIO: Linear PCM, 16bit, 48kHz, 2ch	Output Level and Impedance	XLR: +22 dBu (Maximum: +22 dBu, 600 ohms) RCA phono: -10 dBu (Maximum: +8 dBu, 11 k ohms) Headphones: 25 mW + 25 mW, 20 ohms
	Audio Effects	Channel Effects: Compressor, Noise Gate, 3-Band EQ, Delay Master Effects: Mastering, 3-Band EQ, Reverb	Audio Formats	SDI: Linear PCM, 24bit, 48kHz, 2ch * SMPTE 299M, SMPTE 272M-C HDMI: Linear PCM, 24bit, 48kHz, 2ch USB-AUDIO: Linear PCM, 16bit, 48kHz, 2ch
	Remote	Remote MIDI: 5 pin DIN type (IN, OUT/THRU) RS-232C: D-sub 9 pin type x 1	Audio Effects	Channel Effects: Compressor, Noise Gate, 3-Band EQ, Delay Master Effects: Mastering, 3-Band EQ, Reverb
	Interface	USB2.0 port(host): Hi-Speed USB: Type A (for USB memory) USB3.0 port(device): Type B for USB-VIDEO (Super-Speed/Hi-Speed), USB-AUDIO (Full-Speed)	Remote	Remote MIDI: 5 pin DIN type (IN, OUT/THRU) RS-232C: D-sub 9 pin type x 1
	Display	7 inch Graphic color LCD 800 x 480 dots (touch screen)	Interface	USB2.0 port(host): Hi-Speed USB: Type A (for USB memory) USB3.0 port(device): Type B for USB-VIDEO (Super-Speed/Hi-Speed), USB-AUDIO (Full-Speed)
	Power Supply	AC Adaptor DC 24V Secondary AC Adaptor DC 12 V to 16 V (XLR-4-32 type)	Display	7 inch Graphic color LCD 800 x 480 dots (touch screen)
	Current Draw	2.5 A (DC 24V)	Power Supply	AC Adaptor DC 24V Secondary AC Adaptor DC 12 V to 16 V (XLR-4-32 type)
	Dimensions	434 (W) x 306 (D) x 149 (H) mm 17-1/8 (W) x 12-1/16 (D) x 5-7/8 (H) inches	Current Draw	2.5 A (DC 24V)
	Weight	5.3 kg 11 lbs 11 oz (excl. AC adaptor )	Dimensions	434 (W) x 306 (D) x 149 (H) mm 17-1/8 (W) x 12-1/16 (D) x 5-7/8 (H) inches
Operation Temperature	+0 to +40 degrees Celsius +32 to +104 degrees Fahrenheit	Weight	5.3 kg 11 lbs 11 oz (excl. AC adaptor )	
Accessories	AC Adaptor, Power Cord, Owner's Manual	Operation Temperature	+0 to +40 degrees Celsius +32 to +104 degrees Fahrenheit	

\* 0dBu=0.775 Vrms

\* This product is a Class A digital device under FCC part 15.

\* In the interest of product improvement, the specifications and/or appearance of this unit are subject to change without prior notice.

\* This product is intended for use in the following Electromagnetic environments:

E1:residential, E2:commercial and light industrial, E3:urban outdoors, E4:controlled EMC environment, ex. recording studio (broadcasting studio) which are specified in EN55103-1 and EN55103-2.

## Video Block Diagram

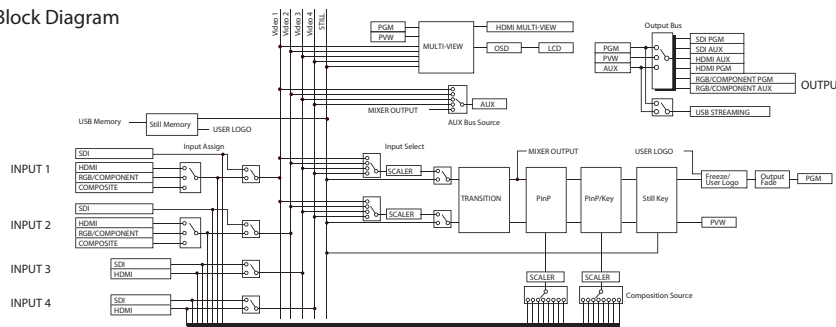

## Dimensions

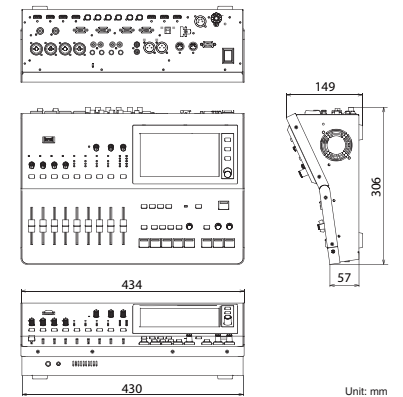

## Audio Block Diagram

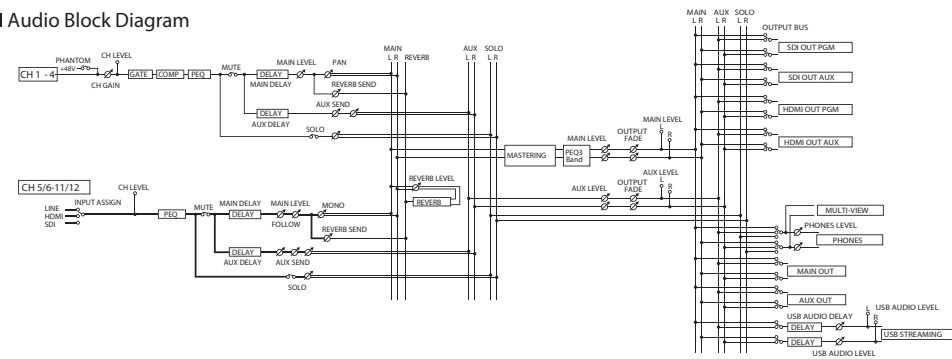

# Roland Systems Group

Roland Systems Group, a member of the worldwide group of Roland companies, is dedicated to the support of audio and video professionals demanding excellence in both performance and system design. Through the development and support of video and audio products, we endeavor to improve workflow and maximize creative possibilities.



MIDI Visual Control is an internationally-used recommended practice that was added to the MIDI specification so that visual expression could be linked with musical performance. Video equipment that is compatible with MIDI Visual Control can be connected to electronic musical instruments via MIDI in order to control video equipment in tandem with a performance.

www.rolandssystemsgroup.net Ensuring high quality while protecting the environment: Roland is ISO9001 and ISO14001 certified

At Roland, several group companies have obtained ISO9001 certification. In addition, in January 1999, Roland also received ISO14001 international environmental management system certification. We're actively seeking ways to maintain harmony with the environment. (ISO=International Standardization Organization: an organization for the promotion of standardization of international units and terms. They provide different categories of certification: ISO9001 Series certification is a product quality certification for products that undergo a certain level of quality control from the design stage to the after service stage; ISO14001 Series certification is for environment-related standards. Each member of the Roland Group is striving to obtain certification.)

# Roland

All specifications and appearances are subject to change without notice. Company names and product names appearing in this document are registered trademarks or trademarks of their respective owners. Roland is either registered trademark or trademark of Roland Corporation in the United States and/or other countries. It is forbidden by law to make an audio recording, video recording, copy or revision of a third party's copyrighted work (musical work, video work, broadcast, live performance, or other work), whether in whole or in part, and distribute, sell, lease, perform, or broadcast it without the permission of the copyright owner. Do not use this product for purposes that could infringe on a copyright held by a third party. We assume no responsibility whatsoever with regard to any infringements of third-party copyrights arising through your use of this product. Copyright 2013 Roland Corporation. All rights reserved.

2014-10

May 2013 RAM-20041 GEN-PD

Ein Vertriebsprodukt von / Distributed by:

**VIDELCO** Europe Limited – Professionelle Audio-, Video-, Medien-Technik

Fon: +49 (0)2102 / 86 39-00 • Fax: +49 (0)2102 / 86 39-17 • info@videlco.eu • www.videlco.eu